

USER MANUAL

VERSION 2.0 November 2024

ROM VERSION: 4A1APOSAM100

MyVenue MV15

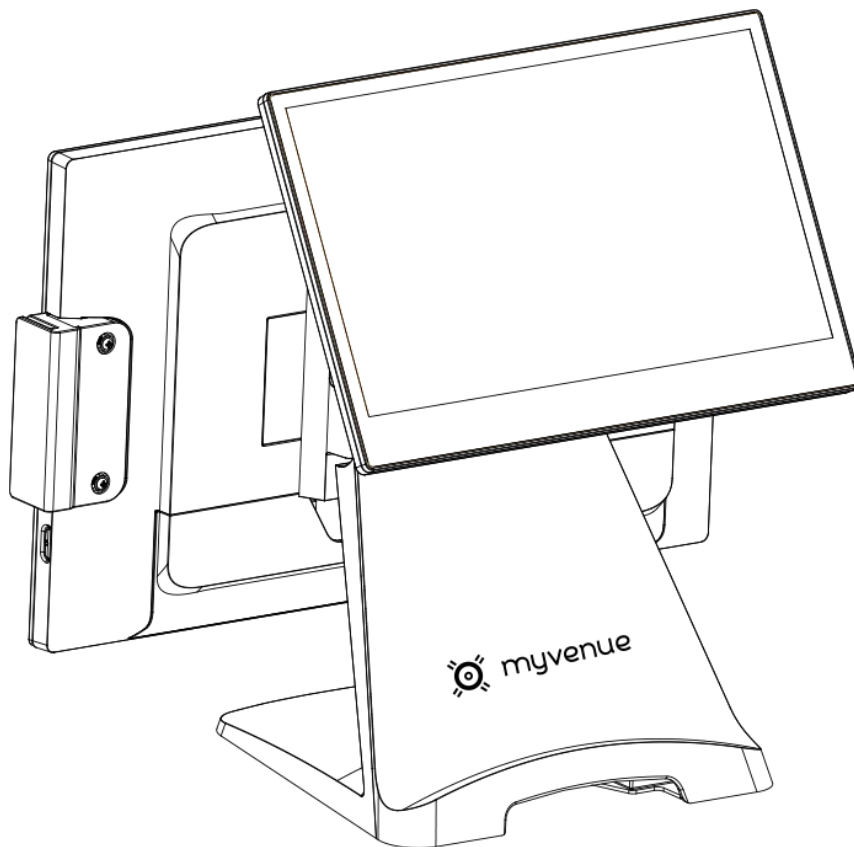

CONTACT

North America: +1 (844) 569-8368

Oceania: +61 1800-961-986

Support Email: support@myvenue.com

www.myvenue.com

The information contained in this document is subject to change without notice. We make no warranty of any kind with regard to this material, including, but not limited to, the implied warranties of merchantability and fitness for a particular purpose. We shall not be liable for errors contained herein or for incidental or consequential damages in connection with the furnishing, performance, or use of this material.

This document contains proprietary information that is protected by copyright. All rights are reserved. No part of this document may be photocopied, reproduced or translated to another language without the prior written consent of the manufacturer.

TRADEMARK

Intel®, Pentium® and MMX are registered trademarks of Intel® Corporation. Microsoft® and Windows® are registered trademarks of Microsoft Corporation. Other trademarks mentioned herein are the property of their respective owners.

Safety

IMPORTANT SAFETY INSTRUCTIONS

1. To disconnect the machine from the electrical power supply, turn off the power switch and remove the power cord plug from the wall socket. The wall socket must be easily accessible and in close proximity to the machine.
2. Read these instructions carefully. Save these instructions for future reference.
3. Follow all warnings and instructions marked on the product.
4. Do not use this product near water.
5. Do not place this product on an unstable cart, stand, or table. The product may fall, causing serious damage to the product.
6. Slots and openings in the cabinet and the back or bottom are provided for ventilation to ensure reliable operation of the product and to protect it from overheating. These openings must not be blocked or covered. The openings should never be blocked by placing the product on a bed, sofa, rug, or other similar surface. This product should never be placed near or over a radiator or heat register or in a built-in installation unless proper ventilation is provided.
7. This product should be operated from the type of power indicated on the marking label. If you are not sure of the type of power available, consult your dealer or local power company.
8. Do not allow anything to rest on the power cord. Do not locate this product where persons will walk on the cord.
9. Never push objects of any kind into this product through cabinet slots as they may touch dangerous voltage points or short out parts that could result in a fire or electric shock. Never spill liquid of any kind on the product.



This device complies with the requirements of the EEC directive 2014/30/EU with regard to “Electromagnetic compatibility” and 2014/35/EU “Low Voltage Directive”.



This device complies with part 15 of the FCC rules. Operation is subject to the following two conditions:

- (1) This device may not cause harmful interference.
- (2) This device must accept any interference received, including interference that may cause undesired operation.

CAUTION ON LITHIUM BATTERIES

There is a danger of explosion if the battery is replaced incorrectly. Replace only with the same or equivalent type recommended by the manufacturer. Discard used batteries according to the manufacturer’s instructions.



Battery Caution

Risk of explosion if battery is replaced by an incorrect type. Dispose of used battery according to the local disposal instructions.



Safety Caution

Note: To comply with IEC60950-1 Clause 2.5 (limited power sources, L.P.S) related legislation, peripherals shall be 4.7.3.2 “Materials for fire enclosure” compliant.

4.7.3.2 Materials for fire enclosures

For MOVABLE EQUIPMENT having a total mass not exceeding 18kg.the material of a FIRE ENCLOSURE, in the thinnest significant wall thickness used, shall be of V-1 CLASS MATERIAL or shall pass the test of Clause A.2.

For MOVABLE EQUIPMENT having a total mass exceeding 18kg and for all STATIONARY EQUIPMENT, the material of a FIRE ENCLOSURE, in the thinnest significant wall thickness used, shall be of 5VB CLASS MATERIAL or shall pass the test of Clause A.1

LEGISLATION AND WEEE SYMBOL

2012/19/EU Waste Electrical and Electronic Equipment Directive on the treatment, collection, recycling and disposal of electric and electronic devices and their components.

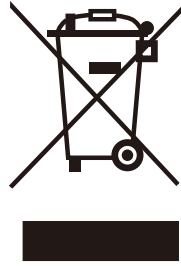

The crossed dust bin symbol on the device means that it should not be disposed of with other household wastes at the end of its working life. Instead, the device should be taken to the waste collection centers for activation of the treatment, collection, recycling and disposal procedure.

To prevent possible harm to the environment or human health from uncontrolled waste disposal, please separate this from other types of waste and recycle it responsibly to promote the sustainable reuse of material resources.

Household users should contact either the retailer where they purchased this product, or their local government office, for details of where and how they can take this item for environmentally safe recycling.

Business users should contact their supplier and check the terms and conditions of the purchase contract.

This product should not be mixed with other commercial wastes for disposal.

Revision History

Changes to the original user manual are listed below:

Revision	Description	Date
1.0	<ul style="list-style-type: none">Initial release	July 2021
1.1	<ul style="list-style-type: none">F14 motherboard added	February 2022
2.0	<ul style="list-style-type: none">F84U motherboard addedF64U motherboard removed	December 2022

Table of Contents

1. Packing List	1
1-1. Standard Accessories	1
1-2. Optional Accessories.....	2
2. System View	3
2-1. Front & Side View	3
2-2. Rear View	3
2-3. IO Ports View.....	4
2-4. Dimensions.....	5
3. System Assembly & Disassembly	6
3-1. Disassemble the Stand	6
3-2. Remove the Cable Cover	6
3-3. Install the Power Adapter.....	7
3-4. Replace the M.2 SSD Card.....	7
4. Peripheral Installation	8
4-1. Install the MSR / Fingerprint / iButton Module	8
4-2. Install the Customer Display	9
4-3. Install the Second Display	10
4-4. Cash Drawer Installation	11

5. Specification..... 13

6. Configuration 15

6-1. F34 Motherboard	15
6-1-1. Motherboard Layout.....	15
6-1-2. Connectors & Functions	16
6-1-3. Jumper Settings	17
6-2. F14 Motherboard	21
6-2-1. Motherboard Layout.....	21
6-2-2. Connectors & Functions	22
6-2-3. Jumper Settings	23
6-3. F84U Motherboard.....	26
6-3-1. Motherboard Layout.....	26
6-3-2. Connectors & Functions	27
6-3-3. Jumper Settings	28

The page is intentionally left blank.

1. Packing List

1-1. Standard Accessories

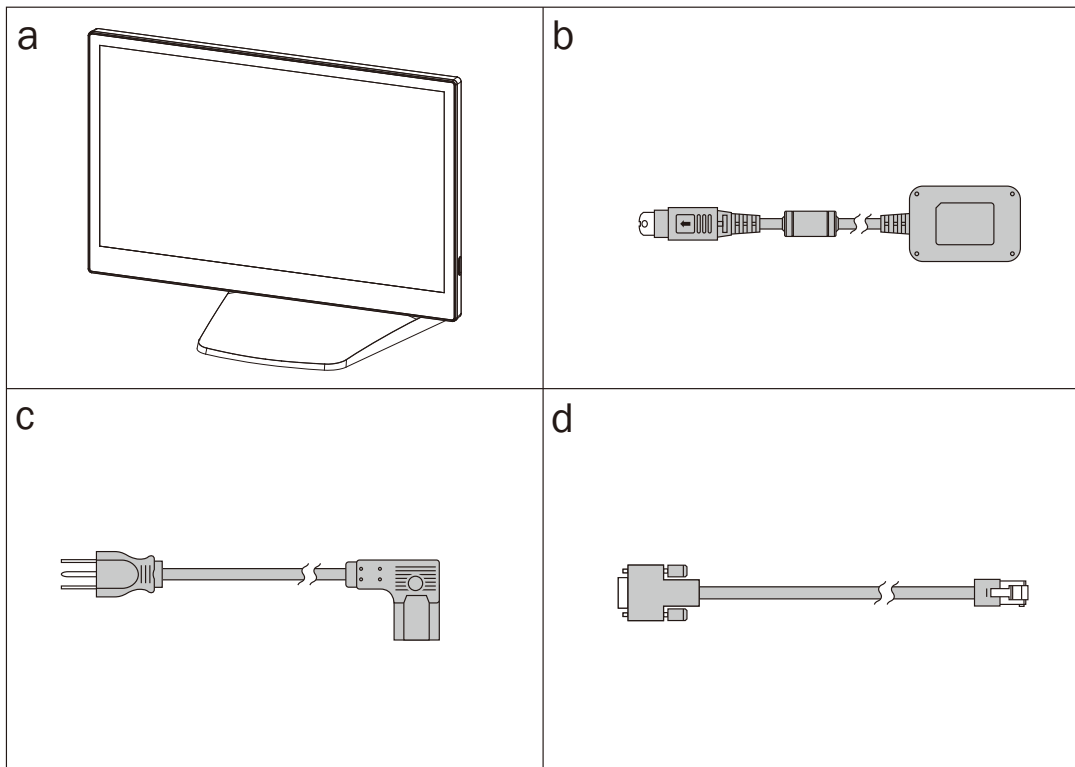

- a. System
- b. Power adapter
- c. Power cord
- d. RJ45-DB9 cable (x2)

Note: Power cords will be supplied differently according to various regions or countries.

1-2. Optional Accessories

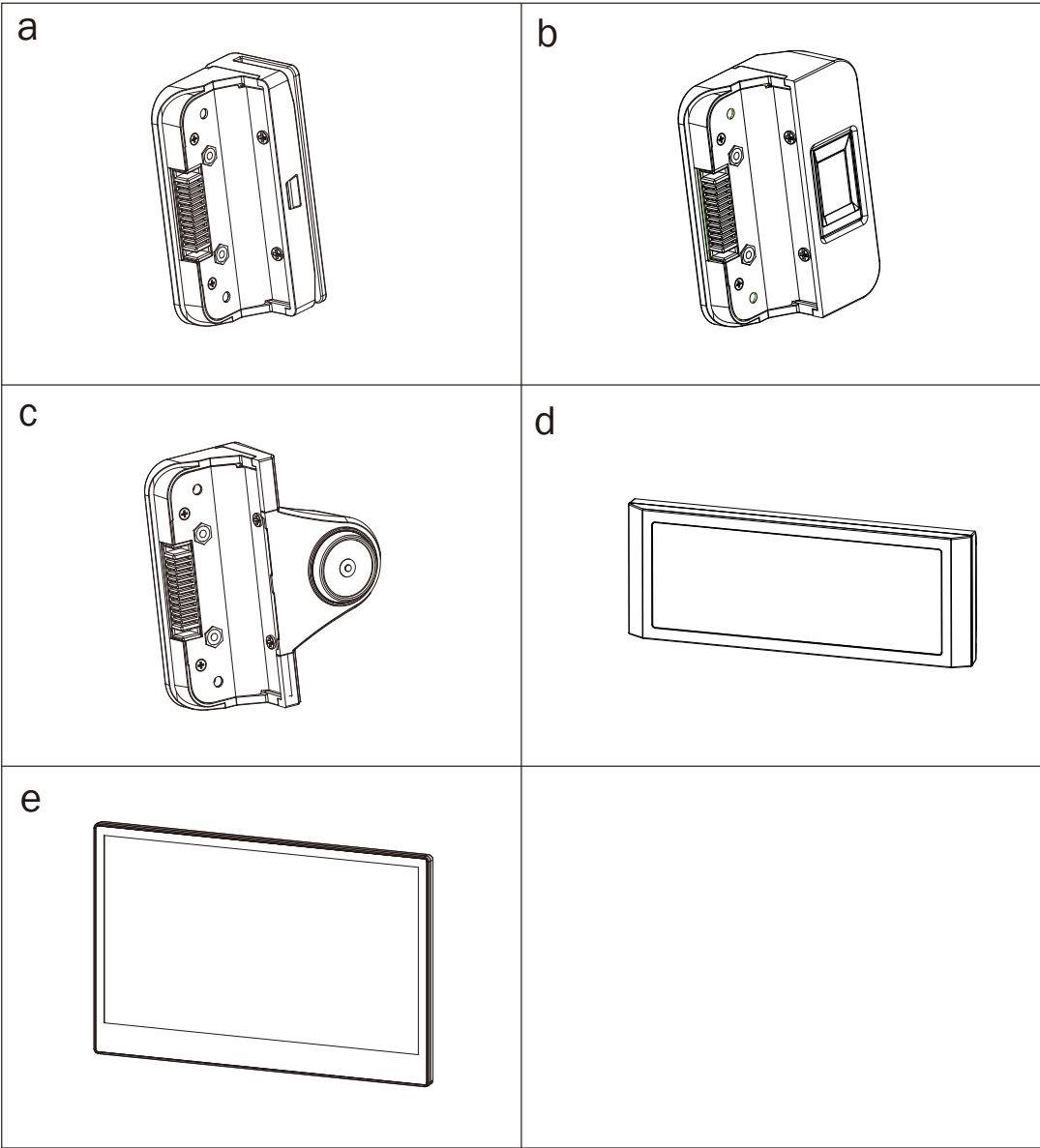

- a. MSR module
- b. Fingerprint module
- c. iButton module
- d. Customer display
- e. 11.6" 2nd display

2. System View

2-1. Front & Side View

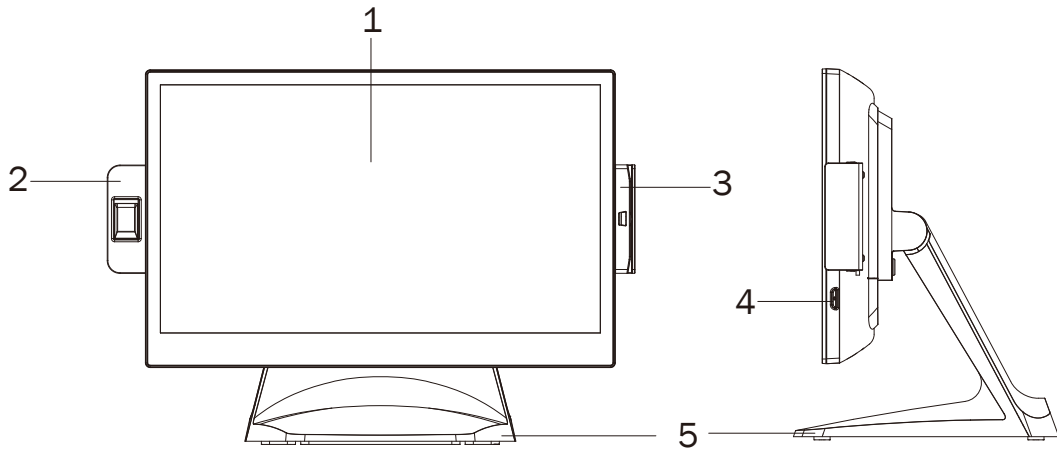

No.	Description
1	Touch screen
2	Fingerprint (option)
3	MSR (option)
4	Power button
5	Stand

2-2. Rear View

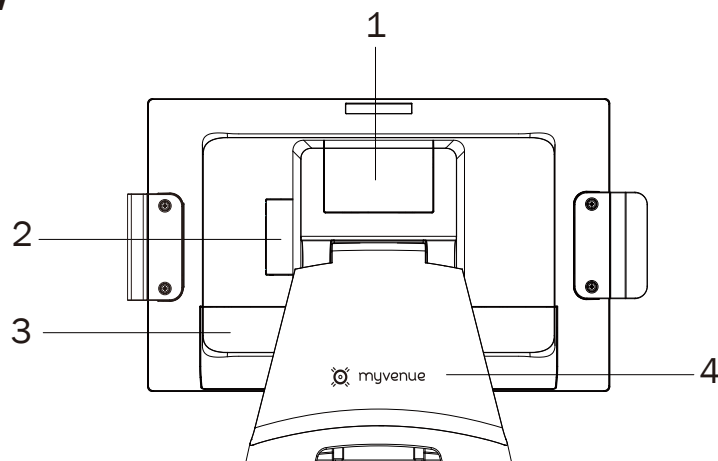

No.	Description
1	VESA top cover
2	SSD door
3	Cable cover
4	Stand cover

2-3. IO Ports View

F34 / F84U Motherboard

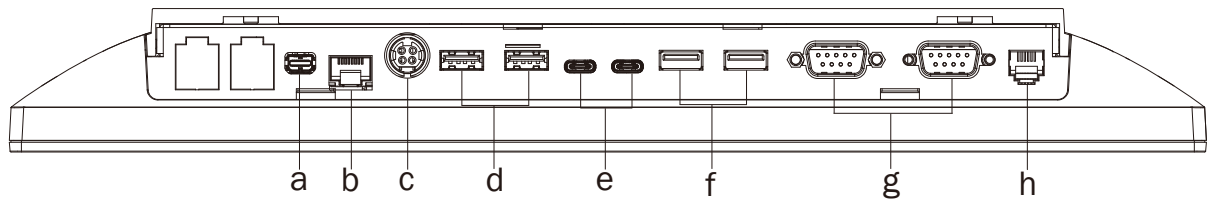

No.	Description
a	FeDP (2 nd display)
b	LAN
c	DC 19V in
d	USB 2.0 x 2
e	USB Type C x 2 (USB2.0)
f	USB 3.0 x 2
g	COM x 2
h	Cash drawer

F14 Motherboard

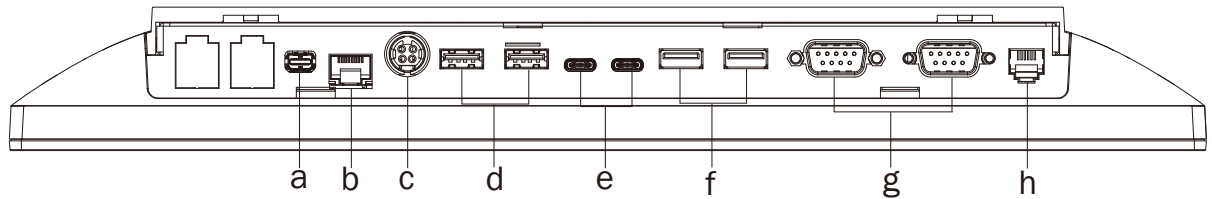

No.	Description
a	FeDP (2 nd display)
b	LAN
c	DC 19V in
d	USB 2.0 x 2
e	USB Type C x 2 (USB3.0)
f	USB 3.0 x 2
g	COM x 2
h	Cash drawer

2-4. Dimensions

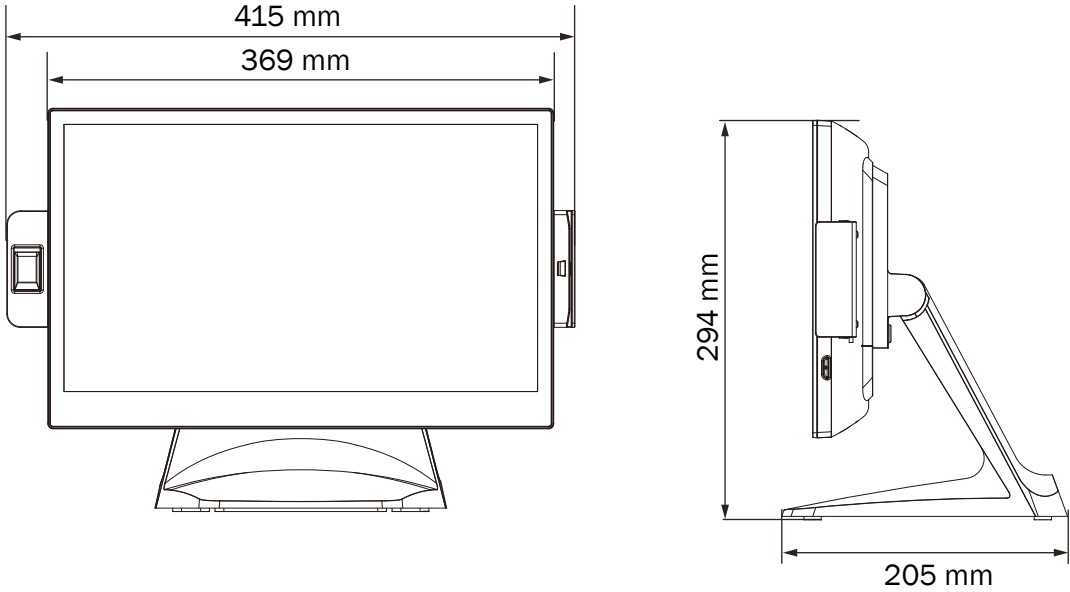

3. System Assembly & Disassembly

3-1. Disassemble the Stand

1. Loosen the thumb screw (x1) and slide the stand towards the IO panel to release it from the system.
2. Reverse the steps above to attach stand to the system.

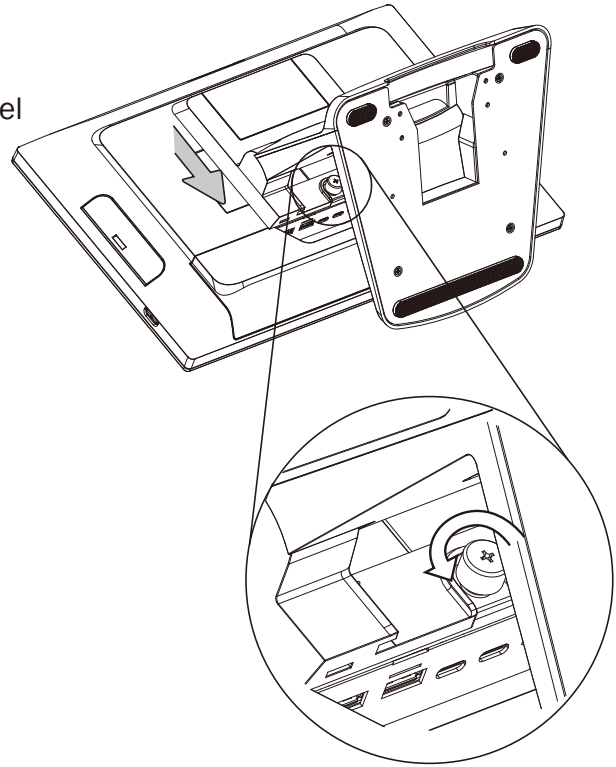

3-2. Remove the Cable Cover

1. Pull the cable cover outwards to release it from the system.

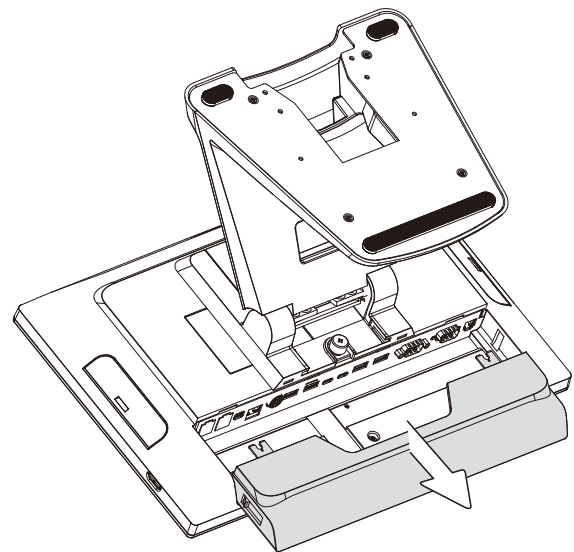

3-3. Install the Power Adapter

The system is equipped with a 65W or 120W power adapter. Please follow the steps to install the power adapter.

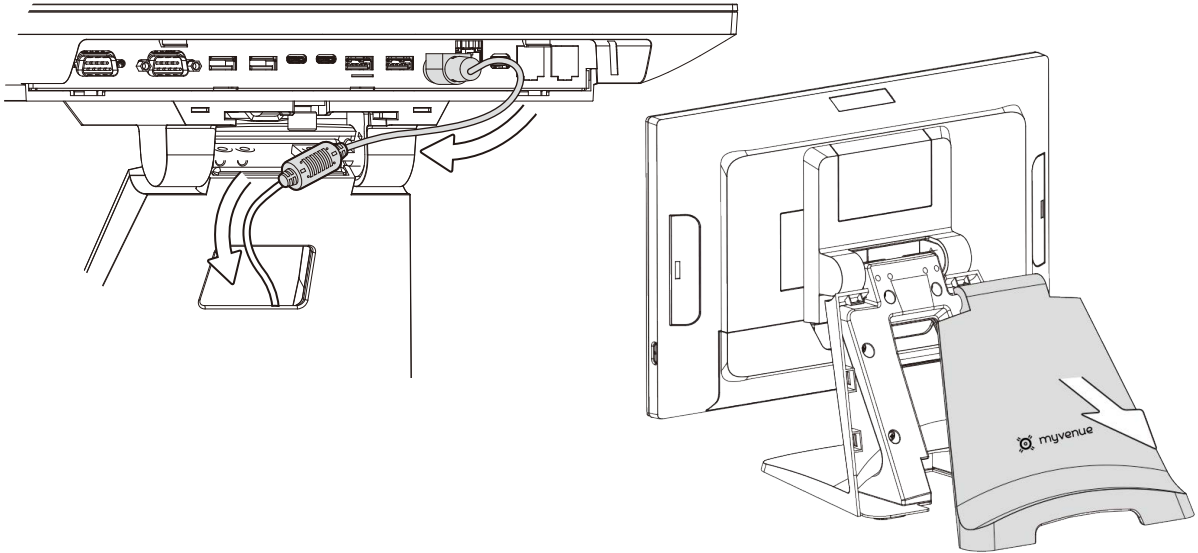

1. Follow the steps described in Chapter 3-2 to release the cable cover first.
2. Connect the power adapter to the 19V DC in port and then route the cable through the hole of the stand as shown in the picture.
3. Open the stand cover and arrange the cable.

3-4. Replace the M.2 SSD Card

1. To replace the M.2 SSD card, please disassemble the stand first as steps described in Chapter 3-1.
2. Remove the screw (x1) to release the SSD dummy cover.

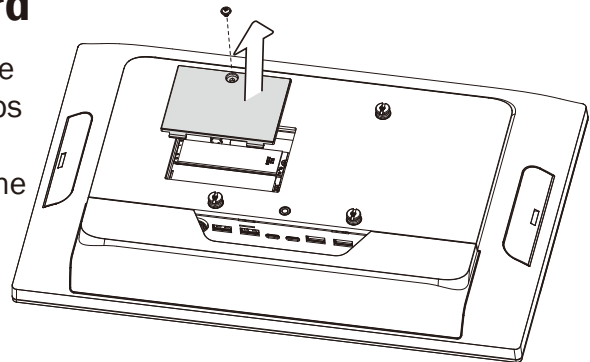

3. Remove the screws (x2) and pull the M.2 SSD cards outwards as shown in the picture.

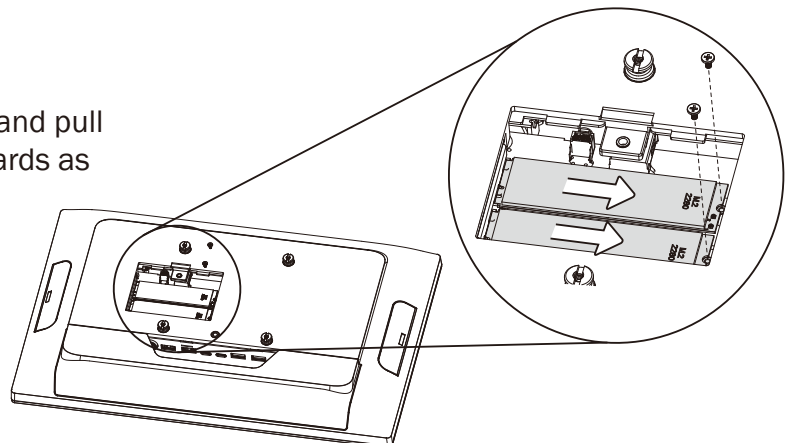

4. Peripheral Installation

4-1. Install the MSR / Fingerprint / iButton Module

1. The variety of peripheral MSR, Fingerprint, and iButton modules can be installed to either side of the system depending on your preference.
2. Remove the dummy cover first.

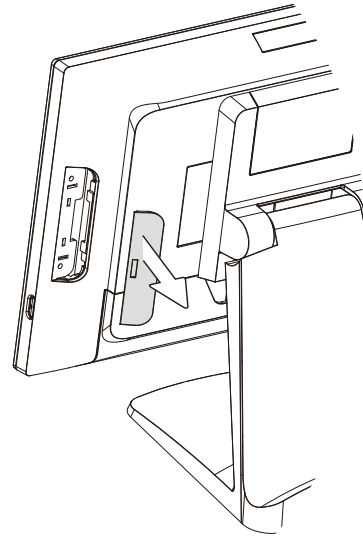

3. Insert the MSR / Fingerprint / iButton module in place and fasten the screws (x2) on the back to secure the module.

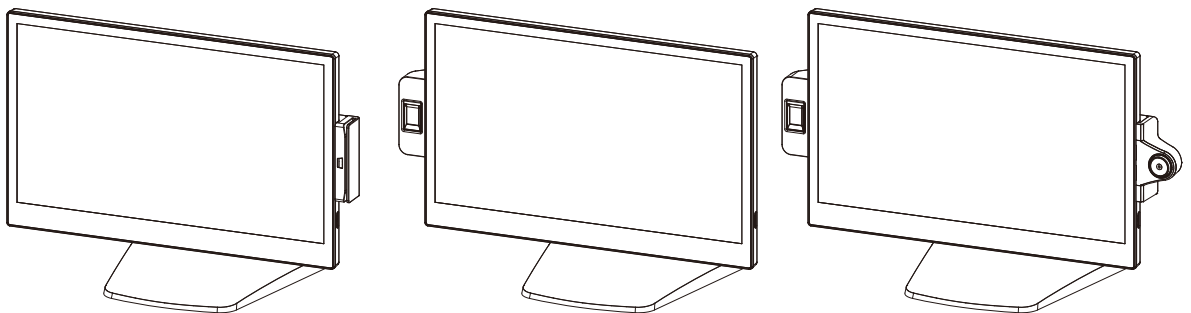
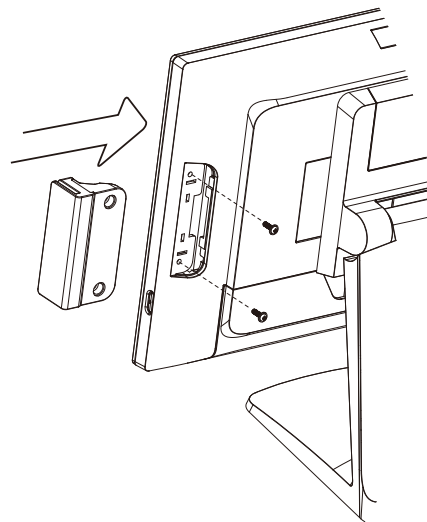

4-2. Install the Customer Display

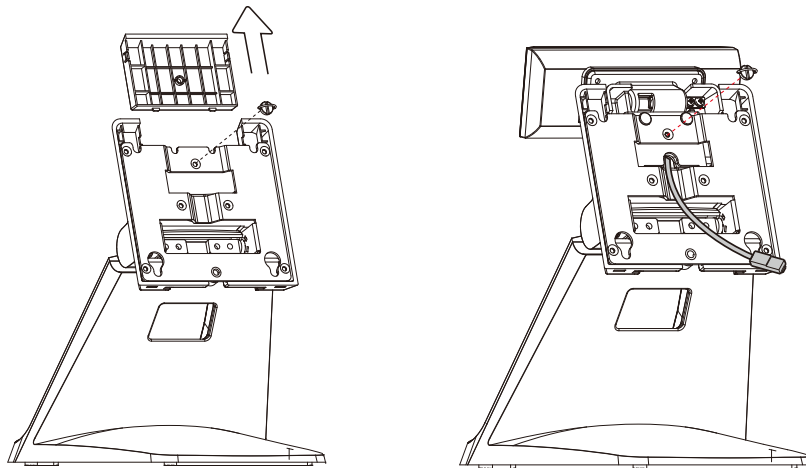

1. Follow the steps in Chapter 3-1 to disassemble the stand from the LCD panel.
 2. Remove the thumb screw (x1) from the VESA top cover and then pull the cover up.
 3. Attach the LCM module to system by fastening the thumb screw (x1).
 4. Route the USB cable through the hole of the stand as pictured.
 5. Attach the stand to the LCD panel and fasten the thumb screw (x1).
 6. Connect the USB cable to the USB port on the systems IO panel. Make sure the system is powered off.
- * Please note the cable cover (refer to Chapter 3-2) has to be removed before routing the cable.

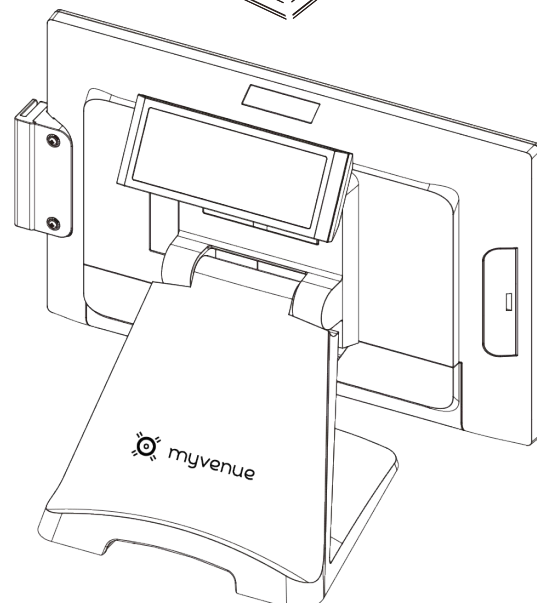
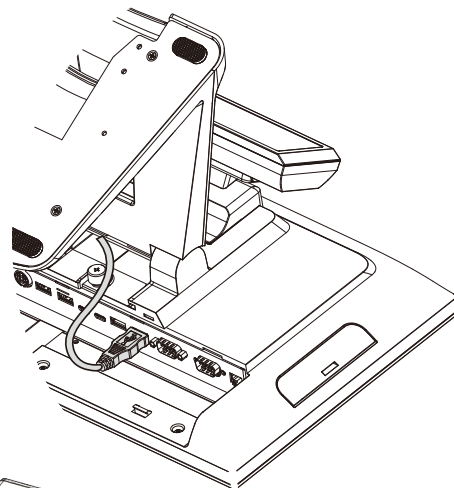

4-3. Install the Second Display

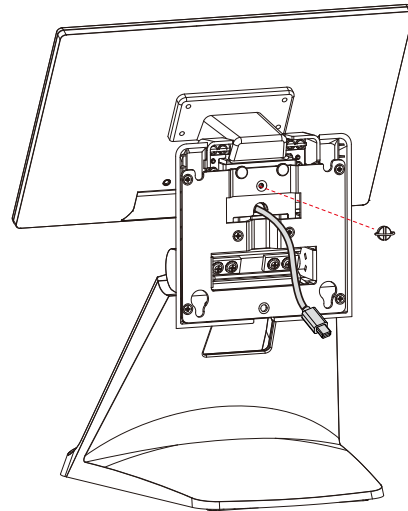
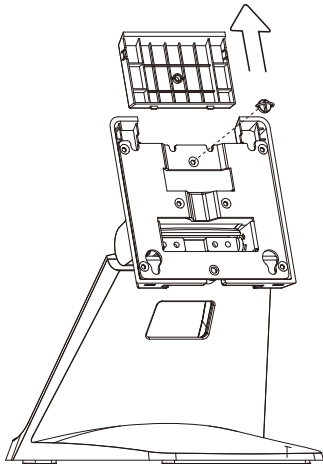

1. Follow the steps in Chapter 3-1 to disassemble the stand from the LCD panel.
2. Remove the thumb screw (x1) from the VESA top cover and then pull the cover up.
3. Attach the 11.6" 2nd display module to system by fastening the thumb screw (x1).
4. Route the mini display cable through the hole of the stand as picture shown.

5. Attach the stand to the LCD panel and fasten the thumb screw (x1).

6. Connect the mini display cable to the FeDP port on the systems IO panel. Make sure the system is powered off.

* Please note the cable cover (refer to Chapter 3-2) has to be removed before routing the cable.

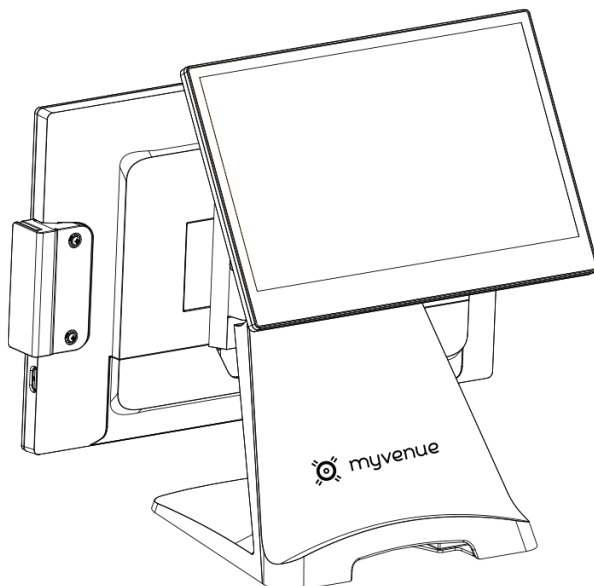
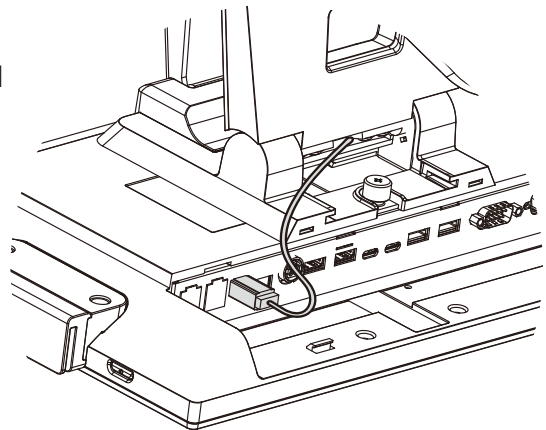

4-4. Cash Drawer Installation

You can install a cash drawer through the cash drawer port. Please verify the pin assignment before installation.

Cash Drawer Pin Assignment

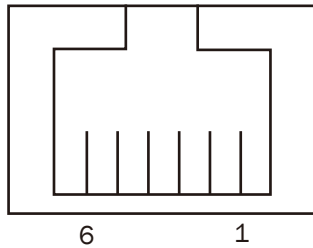

Pin	Signal
1	Cash drawer 2 In
2	Cash drawer 1 Out
3	Cash drawer 1 In
4	12V / 19V
5	Cash drawer 2 Out
6	GND

Cash Drawer Controller Register

The Cash Drawer Controller uses one I/O address to control the Cash Drawer.

Register Location: 0x482h

Attribute: Read / Write

Size: 8bit

BIT	BIT7	BIT6	BIT5	BIT4	BIT3	BIT2	BIT1	BIT0
Attribute	Reserved			CD1 Out	CD1 In	Reserved		

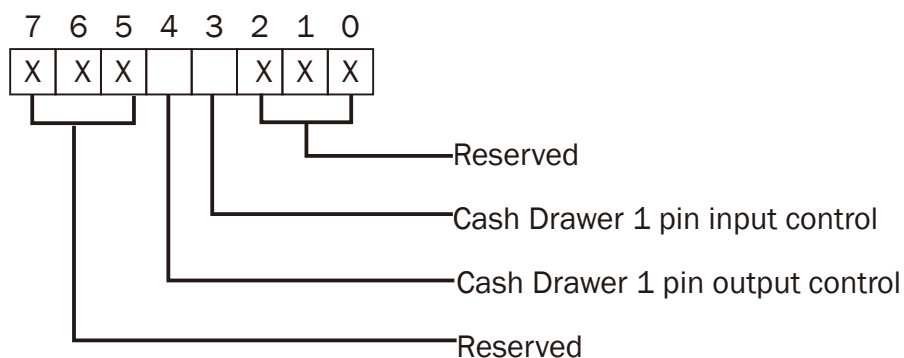

Bit 7: Reserved
 Bit 6: Reserved
 Bit 5: Reserved
 Bit 4: Cash Drawer 1 pin output control.
 = 1: Opening the Cash Drawer
 = 0: Allow close the Cash Drawer
 Bit 3: Cash Drawer 1 pin input control.
 = 1: the Cash Drawer closed or no Cash Drawer
 = 0: the Cash Drawer opened
 Bit 2: Reserved
 Bit 1: Reserved
 Bit 0: Reserved

Note: Please follow the Cash Drawer control signal design to control the Cash Drawer.

Cash Drawer Control Command Example

Command	Cash Drawer
O 482 10	Opening
O 482 00	Allow to close
<ul style="list-style-type: none"> ▶ Set the I/O address 482h bit4 =1 for opening Cash Drawer by “DOUT bit0” pin control. ▶ Set the I/O address 482h bit4 = 0 for closing Cash Drawer. 	

Command	Cash Drawer
I 482	Check status
<ul style="list-style-type: none"> ▶ The I/O address 482h bit3 =1 mean the Cash Drawer is opened or not exist. ▶ The I/O address 482h bit3 =0 mean the Cash Drawer is closed. 	

5. Specification

Model Name	MyVenue MV15		
Mainboard	F34	F84U	F14
CPU support	Intel® Elkhart Lake Celeron J6412	Intel® Tiger Lake i3-1115G4 i5-1135G7	Qualcomm SNM758L-3308 (SnapDragon450)
System memory	DDR4 S.O. DIMM x1, 2133 Mhz (32GB Max)		3GB LPDDR3
Graphic memory	Intel Graphic (Gen 9) DX12, define on CPU		32GB eMMC
LCD Touch Panel			
LCD size	15.6" LED (eDP)		
Brightness (cd/m ²)	220 nits		
Maximal resolution	1920 x 1080		
Touch screen type	True flat (P-CAP)		
Tilt angle	0~90°		
Storage			
Flash Memory	M.2 SATA SSD or NVMe SSD		
Expansion			
m.2 (E-Key) Slot	1x (for WLAN)		
m.2 (m-Key) Slot	1 x M-key 2280 (for storage)		N/A
I/O Ports			
USB Type-A	4 (2 x USB3.0, 2x USB 2.0)		
USB Type-C	1 x USB2.0/USB3.0 data only (w/o MUX)+CC controller (5V only) 1 x USB2.0 data only+CC controller (5V only) or PD source 5/19V (PD option for POS)	1 x USB3.0 Type C (full function), PDO 5V@2A/12V@1.5A 1 x USB2.0 Type C (data only), PDO 5V@2A/ PDO 19V@5A	
Serial / COM	2 x DB9 (COM1 / COM2 w/5V/12V powered enabled by BIOS)		
LAN (10/100/1000)	1 x RJ45		
Cash drawer	1 x RJ-11 (2 in 2 out)		
DC jack	1 (4-pin w/lock)		
FeDP	1 x FeDP (proprietary) miniDP for 2 nd display (2-lane eDP/USB2.0/audio(R-CH)/power button/power)		
Expansion I/O			
Powered USB	1 x powered USB 12V, 1x powered USB 24V		
Power			
Power adapter	65W/19V	120W/19V	65W/19V
Peripherals (optional)			
MSR	1 (USB) (blade type)		
Fingerprint	1 (USB) (blade type)		
iButton	1 (USB) (blade type)		
Second display	11.6" LED Second display (touch option)		

Model Name	MyVenue MV15		
Mainboard	F34	F84U	F14
Customer display	Flush mount LCM display 2 x 20 characters (USB)		
Speaker	1 x 3W		
Control/Indicator			
Power button	1		
Power LED	1 (Blue) on the touchscreen		
Certificate			
EMC & Safety	FCC, Class A, CE, LVD		
ESD	4 kV Contact discharge, 8 kV Air discharge		
Environment			
Sealing	IP54 (front side)		
Operating temperature	0°C ~ 35°C (32°F ~ 95°F)		
Storage temperature	-20°C ~ 60°C (-4°F ~ 140°F)		
Humidity	20% ~ 85% RH non-condensing		
Dimension (W x D x H)	369 x 205 x 294mm		
Weight	6 kg		
OS supported	Windows 10 IoT Enterprise, Linux		Android 10

* This specification is subject to change without prior notice.

6. Configuration

6-1. F34 Motherboard

6-1-1. Motherboard Layout

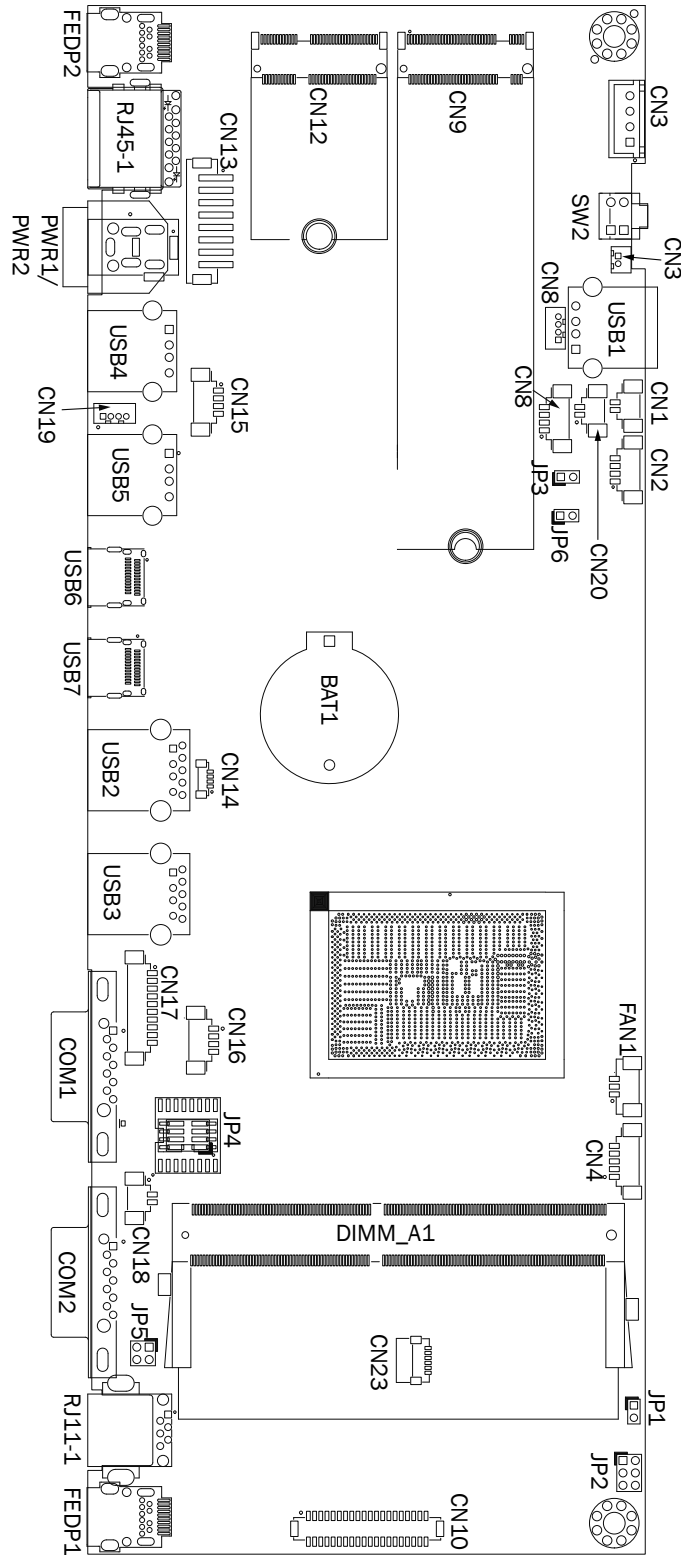

6-1-2. Connectors & Functions

Connector	Function
CN1	Speaker R output
CN2	S0/S5 LED & power button connector
CN3	SATA power connector
CN4	EC Debug
CN5	Speaker L output
CN7	Earphone connector
CN8/CN15/CN16/CN19	Internal USB connector
CN9	M.2 M-KEY PCIE/SATA connector
CN10	Internal eDP connector
CN12	M.2 E-KEY WIFI connector
CN13	Wide range & Power connector
CN18	Storage LED connector
CN20	Mic-out connector
PWR1/PWR2	DC jack (2pin/4pin)
RJ11_1	Cash drawer connector
RJ45_1	LAN connector
SW1/SW2	Power button
DIMM_A1	DDR4 SO-DIMM
FAN1	CPU FAN connector
FeDP1	FeDP main display connector
FeDP2	FeDP 2 nd display connector
USB1/USB4/USB5	USB2.0 connector
USB2/USB3	USB3.0 connector
USB6	USB-C data-only connector (USB3.0/2.0)
USB7	USB-C data-only connector (USB2.0)
COM1/COM2	COM port connector
COM3 (CN17)	Internal COM port connector
BAT1	RTC Battery
JP2	Speaker cable watt setting
JP3	Audio Line-out setting
JP5	Cash drawer power setting

Note: Connectors and jumpers will be different according to product difference, the real object should be considered as final. Contact your POS Systems authorized distributor or reseller for technical information or specific device configuration.

6-1-3. Jumper Settings

Speaker Cable Watt Setting

Function	JP2
▲ L=0.58m	1 3 2 4
L=2.0m	<input type="checkbox"/> 1 3 <input type="checkbox"/> 2 4
M/B	1 <input type="checkbox"/> 3 2 <input type="checkbox"/> 4

Audio Line-out Setting

Function	JP3
▲ Stereo	<input type="checkbox"/> 1 <input type="checkbox"/> 2
Reserved (line-out)	<input type="checkbox"/> 1 <input type="checkbox"/> 2

Cash Drawer Power Setting

Function	JP5
▲ +19V	<input type="checkbox"/> 1 3 <input type="checkbox"/> 2 4
+12V	1 <input type="checkbox"/> 3 2 <input type="checkbox"/> 4

▲ = Manufacturer Default Setting

1 Jumper open 1 Jumper short
 2 Jumper open 2 Jumper short

LCD ID Setting

To set the panel ID, please insert the jumper on the FeDP to LVDS board.

Panel#	Resolution	JP3										
0	Reserved	<table border="1"> <tr><td>1</td><td>3</td><td>5</td><td>7</td><td>9</td></tr> <tr><td>2</td><td>4</td><td>6</td><td>8</td><td>10</td></tr> </table>	1	3	5	7	9	2	4	6	8	10
1	3	5	7	9								
2	4	6	8	10								
1	800 x 600	<table border="1"> <tr><td>1</td><td>3</td><td>5</td><td>7</td><td>9</td></tr> <tr><td>2</td><td>4</td><td>6</td><td>8</td><td>10</td></tr> </table>	1	3	5	7	9	2	4	6	8	10
1	3	5	7	9								
2	4	6	8	10								
2	800 x 600	<table border="1"> <tr><td>1</td><td>3</td><td>5</td><td>7</td><td>9</td></tr> <tr><td>2</td><td>4</td><td>6</td><td>8</td><td>10</td></tr> </table>	1	3	5	7	9	2	4	6	8	10
1	3	5	7	9								
2	4	6	8	10								
3	1024 x 768	<table border="1"> <tr><td>1</td><td>3</td><td>5</td><td>7</td><td>9</td></tr> <tr><td>2</td><td>4</td><td>6</td><td>8</td><td>10</td></tr> </table>	1	3	5	7	9	2	4	6	8	10
1	3	5	7	9								
2	4	6	8	10								
4	1024 x 768	<table border="1"> <tr><td>1</td><td>3</td><td>5</td><td>7</td><td>9</td></tr> <tr><td>2</td><td>4</td><td>6</td><td>8</td><td>10</td></tr> </table>	1	3	5	7	9	2	4	6	8	10
1	3	5	7	9								
2	4	6	8	10								
5	1366 x 768	<table border="1"> <tr><td>1</td><td>3</td><td>5</td><td>7</td><td>9</td></tr> <tr><td>2</td><td>4</td><td>6</td><td>8</td><td>10</td></tr> </table>	1	3	5	7	9	2	4	6	8	10
1	3	5	7	9								
2	4	6	8	10								
6	1366 x 768	<table border="1"> <tr><td>1</td><td>3</td><td>5</td><td>7</td><td>9</td></tr> <tr><td>2</td><td>4</td><td>6</td><td>8</td><td>10</td></tr> </table>	1	3	5	7	9	2	4	6	8	10
1	3	5	7	9								
2	4	6	8	10								
7	1024 x 600	<table border="1"> <tr><td>1</td><td>3</td><td>5</td><td>7</td><td>9</td></tr> <tr><td>2</td><td>4</td><td>6</td><td>8</td><td>10</td></tr> </table>	1	3	5	7	9	2	4	6	8	10
1	3	5	7	9								
2	4	6	8	10								
8	1280 x 1024	<table border="1"> <tr><td>1</td><td>3</td><td>5</td><td>7</td><td>9</td></tr> <tr><td>2</td><td>4</td><td>6</td><td>8</td><td>10</td></tr> </table>	1	3	5	7	9	2	4	6	8	10
1	3	5	7	9								
2	4	6	8	10								
9	1440 x 900	<table border="1"> <tr><td>1</td><td>3</td><td>5</td><td>7</td><td>9</td></tr> <tr><td>2</td><td>4</td><td>6</td><td>8</td><td>10</td></tr> </table>	1	3	5	7	9	2	4	6	8	10
1	3	5	7	9								
2	4	6	8	10								
15	1920 x 1080	<table border="1"> <tr><td>1</td><td>3</td><td>5</td><td>7</td><td>9</td></tr> <tr><td>2</td><td>4</td><td>6</td><td>8</td><td>10</td></tr> </table>	1	3	5	7	9	2	4	6	8	10
1	3	5	7	9								
2	4	6	8	10								

1
2

 Jumper open

1
2

 Jumper short

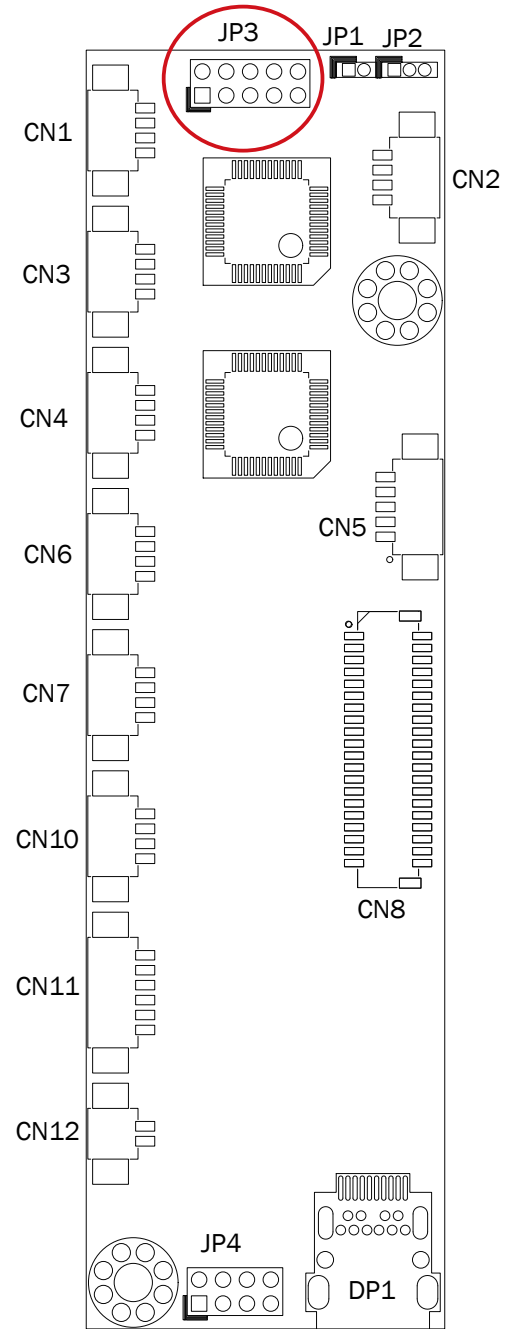

Panel Backlight Current Setting

LED current	JP4
200mA	1 3 5 7 2 4 6 8
240mA	1 3 5 7 2 4 6 8
280mA	1 3 5 7 2 4 6 8
320mA	1 3 5 7 2 4 6 8
360mA	1 3 5 7 2 4 6 8
400mA	1 3 5 7 2 4 6 8
420mA	1 3 5 7 2 4 6 8
460mA	1 3 5 7 2 4 6 8
500mA	1 3 5 7 2 4 6 8

1 Jumper open 1 Jumper short
2 Jumper open 2 Jumper short

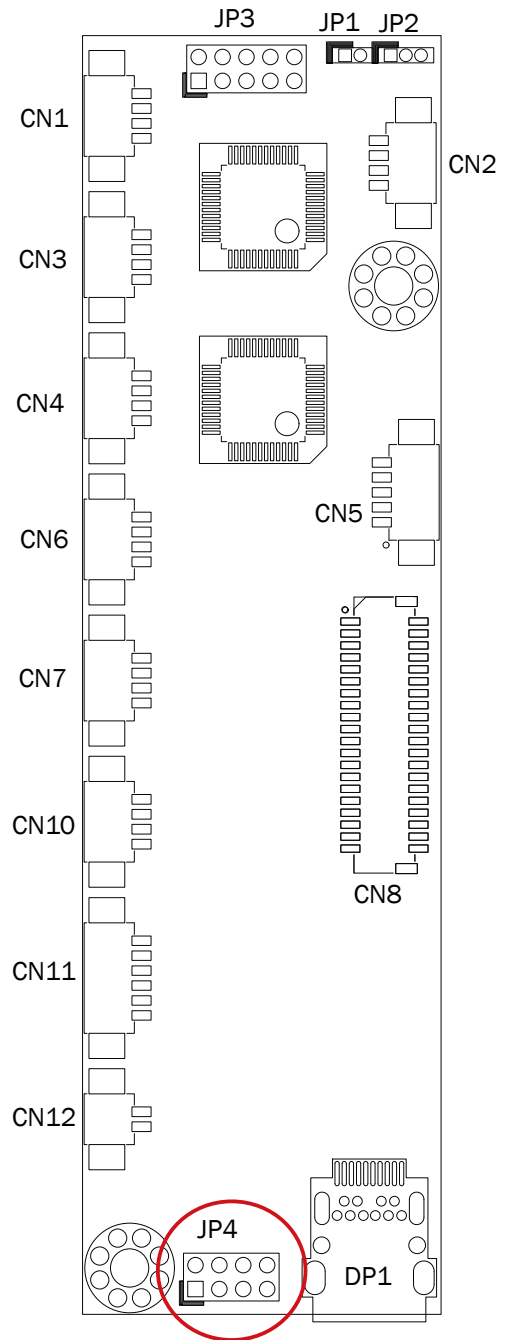

COM1/COM2 Power Setting

COM1, COM2 can be set to provide power to your serial device.
The voltage can be set to +5V or +12V in the BIOS.

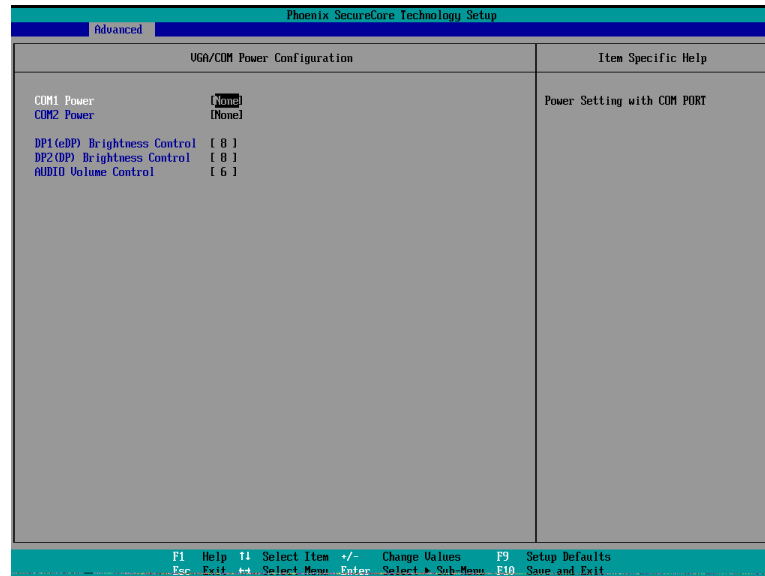

1. Power on the system, and press the key when the system is booting up to enter the BIOS Setup utility.
2. Select the Advanced tab.
3. Select **VGA/COM Power Configuration** Ports and press <Enter> to display the available options.
4. To enable the power, select COM1, COM2 Power setting and press <Enter>. Select Power and press <Enter>. Save the change by pressing F10.

6-2. F14 Motherboard

6-2-1. Motherboard Layout

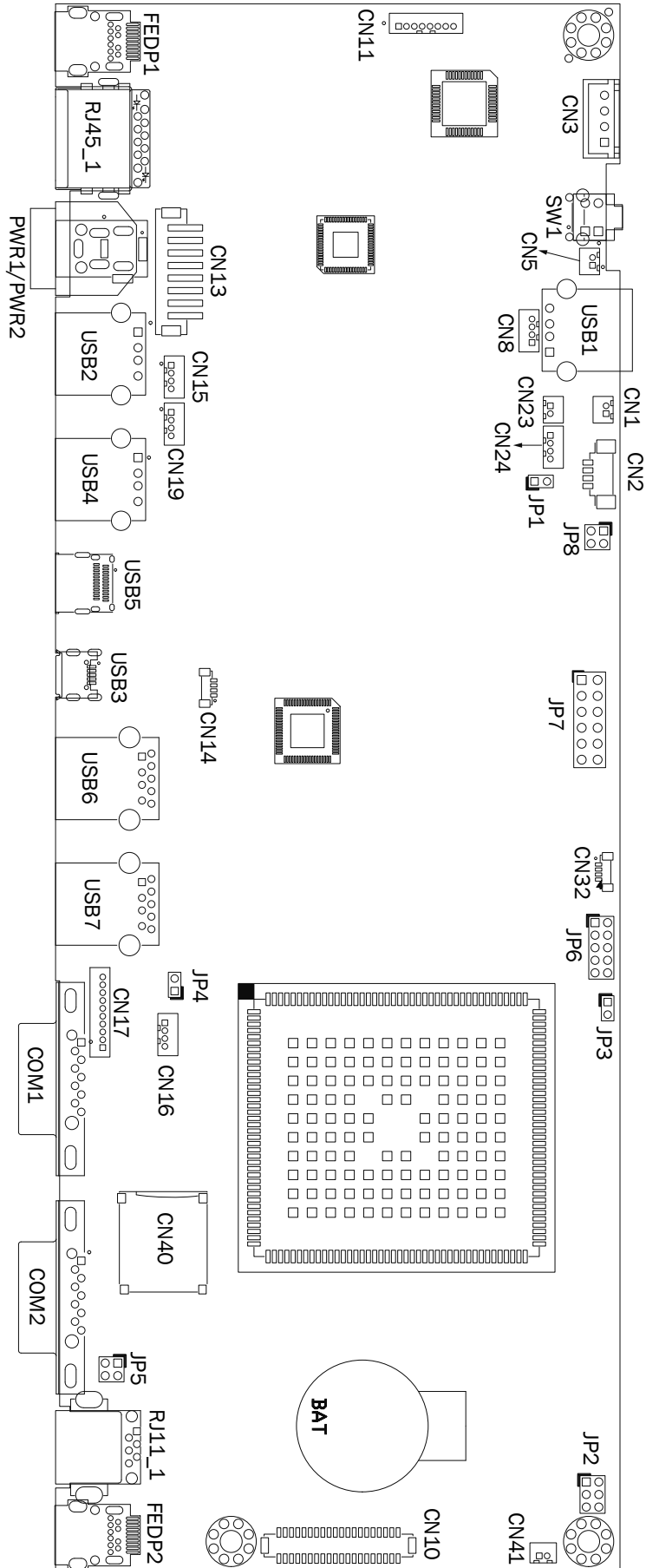

6-2-2. Connectors & Functions

Connector	Function
CN1	Speaker_R connector
CN2	Power LED connector
CN3	SATA power connector
CN5	Speaker_L connector
CN8/15/16/19	USB port (internal) connector
CN10	40pin external connector
CN11	MCU debug connector
CN13	Wide range connector
CN17	COM3 connector
CN18	WIFI 5G connector
CN21	WIFI 2.4G connector
CN23	Analog Mic in connector
CN24	Line out connector
CN32	Digital mic connector
CN40	Micro SD card connector
PWR1	DC Jack (2 pin) connector
PWR2	DC Jack (4 pin) connector
RJ11_1	Cash drawer connector
RJ45_1	LAN connector
USB1/USB2/USB4	USB 2.0 connector
USB3	System USB debug connector
USB5	USB type C
USB6/USB7	USB 3.0 connector
FeDP1	2 nd display connector
FeDP2	Main display connector
SW1	Power button
COM1/COM2	RS-232 connector
JP1	Speaker R/L setting
JP2	Speaker watt setting
JP5	Cash drawer power setting
JP8	PoE watt setting

Note: Connectors and jumpers will be different according to product differences, the real object should be considered as final. Contact your POS Systems authorized distributor or reseller for technical information or specific device configuration.

6-2-3. Jumper Settings

Speaker R/L Setting

Function	JP1
R/L separated (two speakers)	<div style="border: 1px solid black; border-radius: 50%; width: 20px; height: 20px; display: flex; align-items: center; justify-content: center; margin: 2px;">1</div> 2
▲ R/L mix(single speaker)	<div style="border: 1px solid black; border-radius: 50%; width: 20px; height: 20px; display: flex; align-items: center; justify-content: center; margin: 2px;">1</div> <div style="border: 1px solid black; border-radius: 50%; width: 20px; height: 20px; display: flex; align-items: center; justify-content: center; margin: 2px;">2</div>

Speaker Watt Setting

Function	JP2
▲ with FeDP cable	1 3 5 2 4 6
without FeDP cable	<div style="border: 1px solid black; border-radius: 50%; width: 20px; height: 20px; display: flex; align-items: center; justify-content: center; margin: 2px;">1</div> 3 5 <div style="border: 1px solid black; border-radius: 50%; width: 20px; height: 20px; display: flex; align-items: center; justify-content: center; margin: 2px;">2</div> 4 6

PoE Mode Setting

Function	JP2
with PoE module	1 3 <div style="border: 1px solid black; border-radius: 50%; width: 20px; height: 20px; display: flex; align-items: center; justify-content: center; margin: 2px;">5</div> 2 4 <div style="border: 1px solid black; border-radius: 50%; width: 20px; height: 20px; display: flex; align-items: center; justify-content: center; margin: 2px;">6</div>

PoE Watt Setting

Function	JP8
▲ 40W	1 3 2 4
51W	<div style="border: 1px solid black; border-radius: 50%; width: 20px; height: 20px; display: flex; align-items: center; justify-content: center; margin: 2px;">1</div> 3 <div style="border: 1px solid black; border-radius: 50%; width: 20px; height: 20px; display: flex; align-items: center; justify-content: center; margin: 2px;">2</div> 4
62W	1 <div style="border: 1px solid black; border-radius: 50%; width: 20px; height: 20px; display: flex; align-items: center; justify-content: center; margin: 2px;">3</div> 2 <div style="border: 1px solid black; border-radius: 50%; width: 20px; height: 20px; display: flex; align-items: center; justify-content: center; margin: 2px;">4</div>

Cash Drawer Power Setting

Function	JP5
▲ +19V	<div style="border: 1px solid black; border-radius: 50%; width: 20px; height: 20px; display: flex; align-items: center; justify-content: center; margin: 2px;">1</div> 3 <div style="border: 1px solid black; border-radius: 50%; width: 20px; height: 20px; display: flex; align-items: center; justify-content: center; margin: 2px;">2</div> 4
+12V	1 <div style="border: 1px solid black; border-radius: 50%; width: 20px; height: 20px; display: flex; align-items: center; justify-content: center; margin: 2px;">3</div> 2 <div style="border: 1px solid black; border-radius: 50%; width: 20px; height: 20px; display: flex; align-items: center; justify-content: center; margin: 2px;">4</div>

1

2

 Jumper open

1

2

 Jumper short

▲ = Manufacturer Default Setting

LCD ID Setting

To set the panel ID, please insert the jumper on the FeDP to LVDS board.

Panel#	Resolution	JP3										
0	Reserved	<table border="1"> <tr><td>1</td><td>3</td><td>5</td><td>7</td><td>9</td></tr> <tr><td>2</td><td>4</td><td>6</td><td>8</td><td>10</td></tr> </table>	1	3	5	7	9	2	4	6	8	10
1	3	5	7	9								
2	4	6	8	10								
1	800 x 600	<table border="1"> <tr><td>1</td><td>3</td><td>5</td><td>7</td><td>9</td></tr> <tr><td>2</td><td>4</td><td>6</td><td>8</td><td>10</td></tr> </table>	1	3	5	7	9	2	4	6	8	10
1	3	5	7	9								
2	4	6	8	10								
2	800 x 600	<table border="1"> <tr><td>1</td><td>3</td><td>5</td><td>7</td><td>9</td></tr> <tr><td>2</td><td>4</td><td>6</td><td>8</td><td>10</td></tr> </table>	1	3	5	7	9	2	4	6	8	10
1	3	5	7	9								
2	4	6	8	10								
3	1024 x 768	<table border="1"> <tr><td>1</td><td>3</td><td>5</td><td>7</td><td>9</td></tr> <tr><td>2</td><td>4</td><td>6</td><td>8</td><td>10</td></tr> </table>	1	3	5	7	9	2	4	6	8	10
1	3	5	7	9								
2	4	6	8	10								
4	1024 x 768	<table border="1"> <tr><td>1</td><td>3</td><td>5</td><td>7</td><td>9</td></tr> <tr><td>2</td><td>4</td><td>6</td><td>8</td><td>10</td></tr> </table>	1	3	5	7	9	2	4	6	8	10
1	3	5	7	9								
2	4	6	8	10								
5	1366 x 768	<table border="1"> <tr><td>1</td><td>3</td><td>5</td><td>7</td><td>9</td></tr> <tr><td>2</td><td>4</td><td>6</td><td>8</td><td>10</td></tr> </table>	1	3	5	7	9	2	4	6	8	10
1	3	5	7	9								
2	4	6	8	10								
6	1366 x 768	<table border="1"> <tr><td>1</td><td>3</td><td>5</td><td>7</td><td>9</td></tr> <tr><td>2</td><td>4</td><td>6</td><td>8</td><td>10</td></tr> </table>	1	3	5	7	9	2	4	6	8	10
1	3	5	7	9								
2	4	6	8	10								
7	1024 x 600	<table border="1"> <tr><td>1</td><td>3</td><td>5</td><td>7</td><td>9</td></tr> <tr><td>2</td><td>4</td><td>6</td><td>8</td><td>10</td></tr> </table>	1	3	5	7	9	2	4	6	8	10
1	3	5	7	9								
2	4	6	8	10								
8	1280 x 1024	<table border="1"> <tr><td>1</td><td>3</td><td>5</td><td>7</td><td>9</td></tr> <tr><td>2</td><td>4</td><td>6</td><td>8</td><td>10</td></tr> </table>	1	3	5	7	9	2	4	6	8	10
1	3	5	7	9								
2	4	6	8	10								
9	1440 x 900	<table border="1"> <tr><td>1</td><td>3</td><td>5</td><td>7</td><td>9</td></tr> <tr><td>2</td><td>4</td><td>6</td><td>8</td><td>10</td></tr> </table>	1	3	5	7	9	2	4	6	8	10
1	3	5	7	9								
2	4	6	8	10								
15	1920 x 1080	<table border="1"> <tr><td>1</td><td>3</td><td>5</td><td>7</td><td>9</td></tr> <tr><td>2</td><td>4</td><td>6</td><td>8</td><td>10</td></tr> </table>	1	3	5	7	9	2	4	6	8	10
1	3	5	7	9								
2	4	6	8	10								

1		1
2	Jumper open	2
	Jumper short	

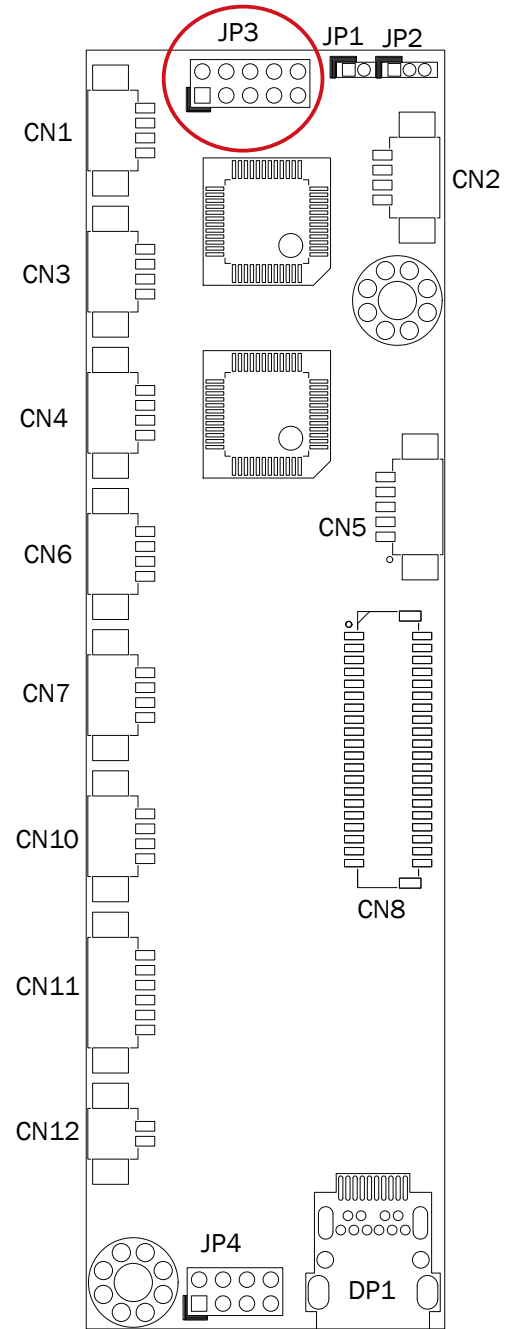

Panel Backlight Current Setting

LED current	JP4
200mA	1 3 5 7 2 4 6 8
240mA	1 3 5 7 2 4 6 8
280mA	1 3 5 7 2 4 6 8
320mA	1 3 5 7 2 4 6 8
360mA	1 3 5 7 2 4 6 8
400mA	1 3 5 7 2 4 6 8
420mA	1 3 5 7 2 4 6 8
460mA	1 3 5 7 2 4 6 8
500mA	1 3 5 7 2 4 6 8

1 Jumper open 1 Jumper short
2 Jumper open 2 Jumper short

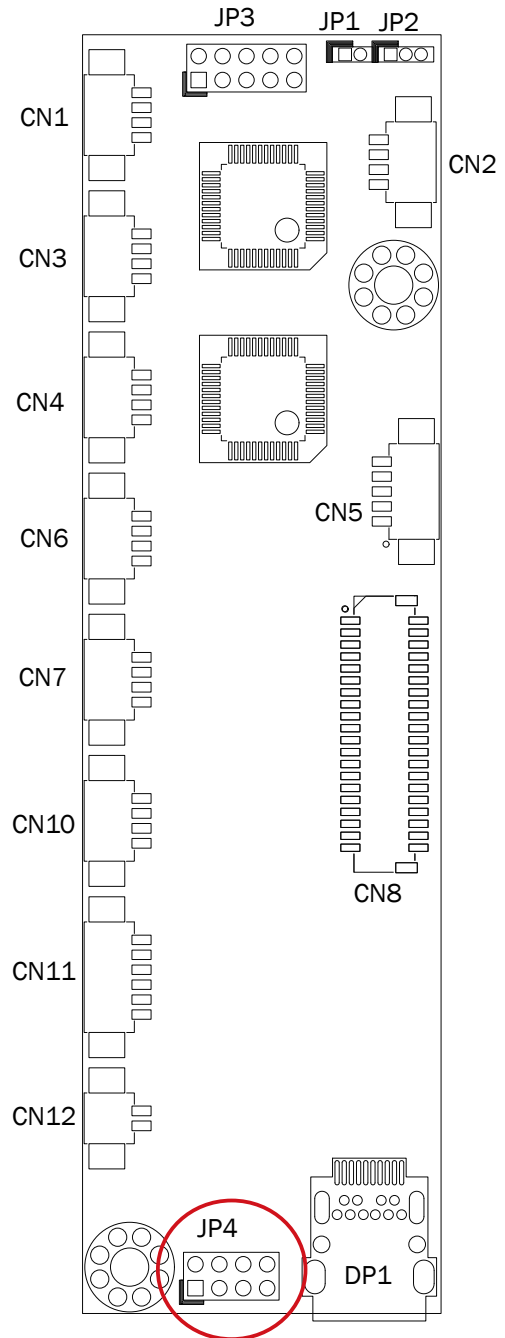

6-3. F84U Motherboard

6-3-1. Motherboard Layout

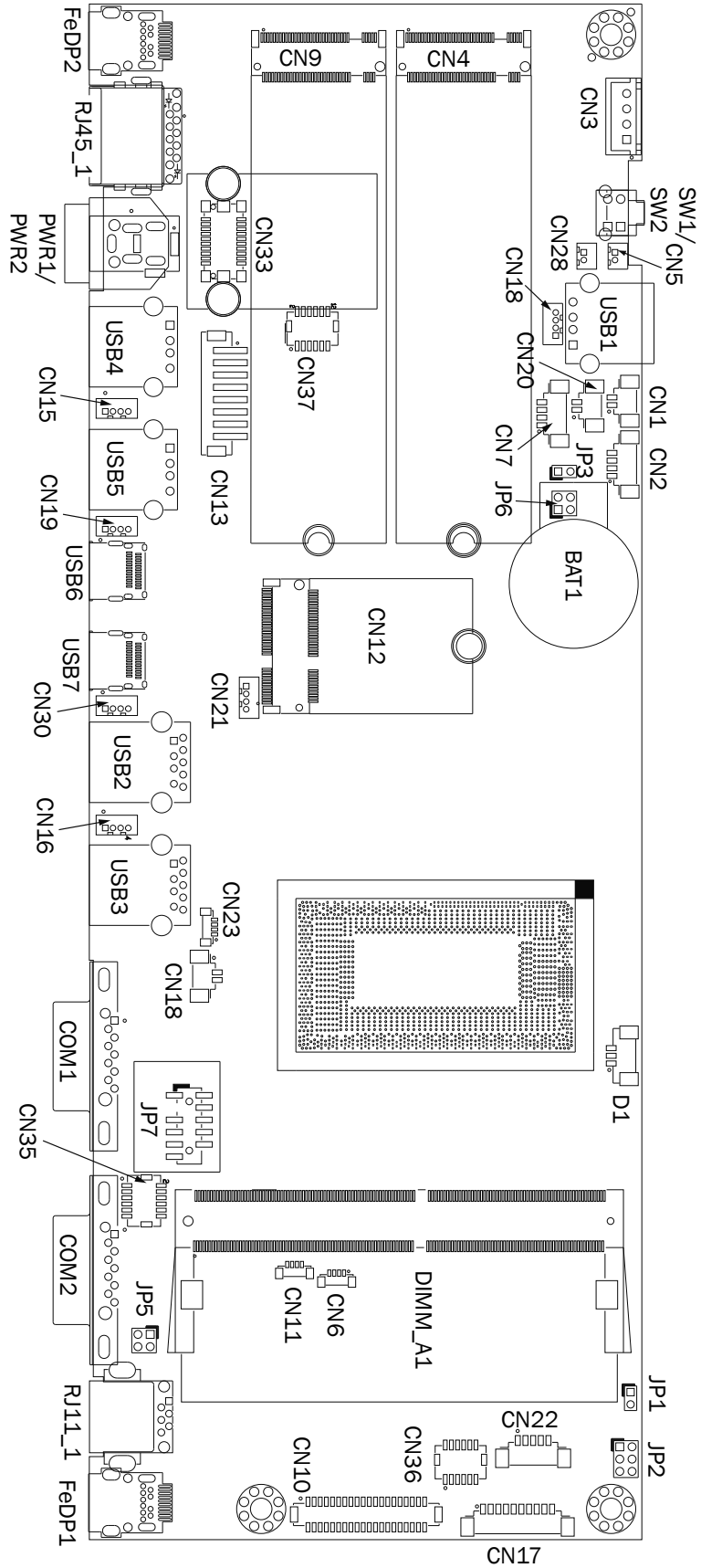

6-3-2. Connectors & Functions

Connector	Function
CN1	Speaker R connector
CN2	4 pin power button w/2 LED
CN3	SATA power connector
CN4	M.2 SSD key M (CPU PCIE4)
CN5	Speaker L connector
CN7	Audio line out connector
CN9	M.2 SSD key M (PCIE GEN3)
CN10	40 pin eDP connector
CN12	M.2 E-KEY WIFI connector
CN13	Powered USB connector
CN15/16/19/30	Internal USB 2.0 connector
CN17	COM3 connector
CN18	HDD LED connector
CN20	Mic-in connector
CN28	Battery 3.0 connector
CN33	OOB connector
PWR1	DC jack (2 pin) connector
PWR2	DC jack (4 pin) connector
RJ11_1	Cash drawer connector
RJ45_1	LAN connector
SW1/SW2	Power button w/LED
DIMM_A1	DDR4 SO-DIMM
FAN1	CPU FAN connector
FeDP1	FeDP main display connector
FeDP2	FeDP 2 nd display connector
USB1/CN8	USB2.0 connector (front USB, option)
USB2/USB3	USB3.0 connector
USB4/USB5	USB2.0 connector
USB6	USB type C (DP / USB3.0)
USB7	USB type C
COM1/COM2	COM port connector
JP2	Speaker cable setting
JP3	Audio Line-out setting
JP5	Cash drawer power setting
JP6	Speaker selection (AD52068)
JP7	TPM connector

Note: Connectors and jumpers will be different according to product differences, the real object should be considered as final. Contact your POS Systems authorized distributor or reseller for technical information or specific device configuration.

6-3-3. Jumper Settings

Audio Line-out Setting

Function	JP3		
▲ Stereo	<table border="1"> <tr><td>1</td></tr> <tr><td>2</td></tr> </table>	1	2
1			
2			
Reserved (line-out)	<table border="1"> <tr><td>1</td></tr> <tr><td>2</td></tr> </table>	1	2
1			
2			

Cash Drawer Power Setting

Function	JP5				
▲ +19V	<table border="1"> <tr><td>1</td><td>3</td></tr> <tr><td>2</td><td>4</td></tr> </table>	1	3	2	4
1	3				
2	4				
+12V	<table border="1"> <tr><td>1</td><td>3</td></tr> <tr><td>2</td><td>4</td></tr> </table>	1	3	2	4
1	3				
2	4				

Speaker Selection (AD52068)

Function	JP6				
▲ Internal & FeDP (3W)	<table border="1"> <tr><td>1</td><td>3</td></tr> <tr><td>2</td><td>4</td></tr> </table>	1	3	2	4
1	3				
2	4				
Internal (2W)	<table border="1"> <tr><td>1</td><td>3</td></tr> <tr><td>2</td><td>4</td></tr> </table>	1	3	2	4
1	3				
2	4				

1
2

 Jumper open

1
2

 Jumper short

▲ = Manufacturer Default Setting

COM1/COM2 Power Setting

COM1, COM2 can be set to provide power to your serial device.
The voltage can be set to +5V or +12V in the BIOS.

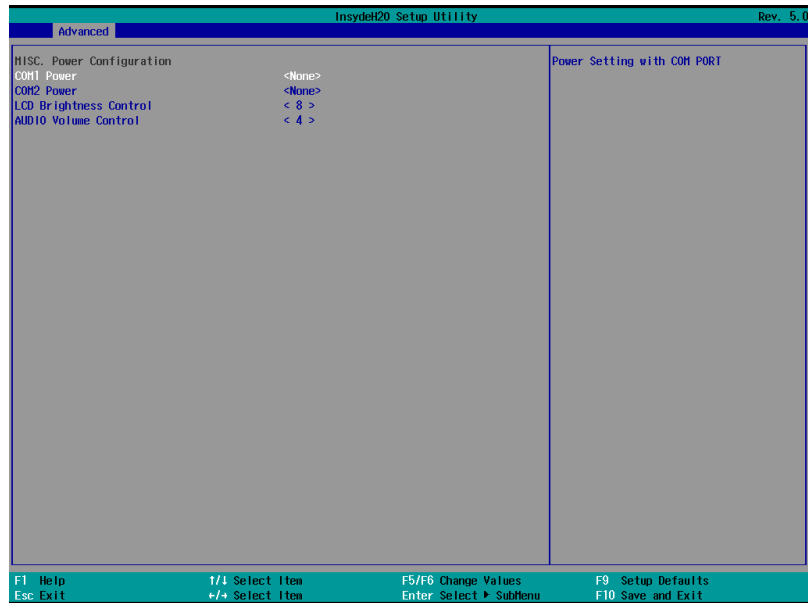

1. Power on the system, and press the key when the system is booting up to enter the BIOS Setup utility.
2. Select the Advanced tab.
3. Select **MISC. Power Configuration** Ports and press <Enter> to go to display the available options.
4. To enable the power, select COM1, COM2 Power setting and press <Enter>. Select Power and press <Enter>. Save the change by pressing F10.